



AEM, INC.

MASTER COPY

**6610 Cobra Way
San Diego, California 92121
(858) 481-0210**

SPECIFICATION SHEET

P600L CURRENT LIMITING FUSE

REVISION:	A	B	C	D	E	F	G	H	J	K	M
DATE:	11/87	5/90	5/92	7/94	6/95	12/95	6/96	1/97	11/99	12/99	5/16
DRAWN:	Jeff Montgomery										
CHECKED:	Mike Van Linge										
APPROVED:	Jeff Montgomery										
ECN:	2184						SHEET 1 OF 27				

1. SCOPE

1.1 Scope. This specification establishes the requirements for thick film current limiting fuses. Fuses described in this document are designed and manufactured for high reliability applications based on guaranteed blow limits. These fuses are intended for use in direct (DC) and alternating current (AC) circuits and are capable of operation over a temperature range of -55°C to +125°C ambient including high vacuum environments.

2. LOT ACCEPTANCE TESTING

2.1 Lot Acceptance Testing. This specification provides for two acceptance levels for the procurement of fuses. The degree of testing and associated documentation can be specified as appropriate to the end use of the fuses. Regardless of the acceptance level specified, the inherent quality and reliability of the fuses will remain constant. The acceptance levels with the applicable inspection required are indicated in Table I.

TABLE I. LOT ACCEPTANCE LEVEL.

Lot Acceptance Level	INSPECTIONS TO BE PERFORMED		
	Group A	Group B	Group C
LAT 2	Required	Required	Not Required
LAT 1	Required	Required	Required

3. APPLICABLE DOCUMENTS

3.1 Issues of Documents. The following specifications, standards and handbooks form a part of this specification to the extent specified herein. In the event of a conflict between the documents referenced herein and this specification, this specification governs.

SPECIFICATIONS

- MIL-PRF-23419: General Specification for Instrument Type Fuses.
- AS9100: Quality Management System Requirements for Aviation, Space and Defense Organizations.

STANDARDS

- MIL-STD-202: Test Methods for Electronic and Electrical Component Parts.
- MIL-STD-790: Reliability Assurance Program for Electronic Parts Specifications.
- MIL-STD-1285: Marking of Electrical and Electronic Parts.
- MIL-STD-45662: Calibration System Requirements

OTHERS

- NCSL Z540.3: Requirements for Calibration of Measuring and Test Equipment.
- J-STD-004: Requirements for Soldering Fluxes.

AEM, Inc.	6610 COBRA WAY SAN DIEGO, CA 92121	TITLE P600L SPECIFICATION
NUMBER P600L	REVISION M ECN 2184	SHEET 2 of 27

J-STD-006:	Requirements for Electronic Grade Solder Alloys.
P600L-PA:	Internal Visual Examination (Precap) for Current Limiting Fuses.
P600L-R:	Radiographic Inspection for Current Limiting Fuses.
SAE-AMS2422:	Plating, Gold.
ASTM E595:	Materials from Outgassing in a Vacuum Environment, Total Mass Loss and Collected Volatile Condensable, Standard Test Method for.
ASTM B488:	Standard Specification for Electrodeposited Coatings of Gold for Engineering Uses.

4. REQUIREMENTS

4.1 Qualification. Fuses manufactured in accordance with this document shall be capable of passing the qualification requirements specified in Table V and section 4 of this document.

4.2 Materials, Design and Construction. The materials, design and construction of the fuses shall be as specified herein (see Figure 6 for flow chart of operations).

4.2.1 Terminals. The lead material shall be CDA-102 copper, plated with gold per SAE-AMS2422 and ASTM B488 and includes the following exception to SAE-AMS2422: The gold underplate shall consist of a minimum of 50 micro-inches of nickel. The Knoop Hardness range shall be an ASTM code C. Fuses may be ordered with hot solder dipped terminals (see paragraph 6.2).

4.2.2 Housing. The housing material shall be polyphenylene sulfide (PPS). The PPS material will be insert molded to form the body of the fuse.

4.3 Voltage Rating. The voltage ratings for fuses specified herein are 50 volts DC, 72 volts DC and 125 volts DC. Nonstandard fuses with voltage ratings of 80 and 135 volts DC are also available. The applicable voltage ratings are specified in Table VI (see note 4 for 135 volt ratings and note 5 for 80 VDC ratings).

4.4 Current Rating. The current rating is the maximum amperes that the fuse will carry at a case temperature of +25°C without degradation. The applicable current ratings are specified in Table VI.

4.5 Temperature Rating. The temperature rating for fuses specified herein is -55°C to +150°C nonoperating. The maximum operating temperature shall not exceed a case temperature of +125°C. The temperature derating curve is given in Figure 5.

4.6 Resistance Rating. The DC resistance of the fuses shall be as specified in Table VI when measured in accordance with 5.8.2.

4.7 Marking. Fuses shall be marked in accordance with Method I of MIL-STD-1285. Adhesive type mylar labels used in serialization will be suitably protected with a clear epoxy. The following information shall be marked on each fuse:

- a) AEM Part Number (see Table VI)
- b) Non-recurring serial number
- c) Voltage rating (VDC)
- d) Current rating in amperes
- e) Manufacture lot code (C-Lot)
- f) AEM logo

Note: For marking examples, please refer to Figures 1, 2 and 3.

AEM, Inc.	6610 COBRA WAY SAN DIEGO, CA 92121	TITLE P600L SPECIFICATION
NUMBER P600L	REVISION M	ECN 2184
		SHEET 3 of 27

4.8 Performance.

4.8.1 Thermal Shock. When fuses are tested in accordance with 5.8.3 herein, they shall show no electrical or mechanical damage and there shall be no loosening of the terminals. Their voltage drops shall not change by more than 10 percent from the pre-thermally shocked values.

4.8.2 Burn-in. When fuses are tested in accordance with 5.8.4, they shall not open circuit nor shall their voltage drops change by more than 10 percent from the pre-thermally shocked values. There shall be no mechanical damage as a result of this testing.

4.8.3 Dielectric Strength. When fuses are tested in accordance with 5.8.5, the leakage current shall not exceed 1 milliampere.

4.8.4 X-Ray Inspection. When fuses are tested in accordance with 5.8.6, there shall be no rejections.

4.8.5 Current-Carrying Capacity (Group C / Qualification Only). When fuses are tested in accordance with 5.8.7, they shall show no evidence of mechanical damage and shall carry the current as specified without electrical failure. The temperature of the case or terminals shall at no point rise more than +85°C above the ambient air temperature. The maximum temperature rise for 6.0, 7.5, 10, 15 and 20 ampere fuses shall be +120°C.

4.8.6 Terminal Strength. When fuses are tested in accordance with 5.8.8, the lead terminals shall not break or loosen. The DC resistance values shall not change by more than 10 percent.

4.8.7 Thermal Vacuum (Qualification Only). When fuses are tested in accordance with 5.8.17, they shall not open circuit during the application of derated DC current nor shall there be evidence of arcing or mechanical damage after the test. Fuses that are subjected to the 400 percent overload current test shall "blow" within the time period specified (see Table VI). The DC resistance values of those fuses not subjected to the overload current shall not change by more than 10 percent when measured after thermal vacuum exposure.

4.8.8 Overload Current.

4.8.8.1 Overload Current Characterization. Each fuse lot shall be sampled to assure that blow time limits fall within the limits of Table VI. Each lot shall be truncated to form an inspection lot based upon the Final Voltage Drop after burn-in. The manufacturer shall blow samples (a minimum of 20 samples total) selected from the extremes of the truncated population to insure that their blow times are within the specification. The results of this procedure shall be provided in the "Group A Data" with the lot data package.

4.8.8.2 Overload Current. Fuses randomly selected from a truncated distribution shall be tested in accordance with 5.8.15. The clearing times and the maximum I^2t shall be as specified in Table VI. After clearing, the circuit shall remain open without closing again during a one minute period. The let through energy during the one minute period shall be included in the calculation of I^2t . The blown fuses shall meet the resistance after firing test of 4.8.9.

4.8.9 Resistance after Firing. When blown fuses are tested in accordance with 5.8.16, the minimum resistance shall be 10 megohms. The following exceptions shall apply for fuses with current ratings greater than 5 amperes:

- a) 250% Overload - A resistance value of 100K ohms minimum following the 250% overload test.
- b) Other Overloads - A resistance value of 1 megohm minimum following overload testing.

4.8.10 Moisture Resistance (Group C / Qualification Only). When fuses are tested in accordance with 5.8.9, there shall be no evidence of cracking or peeling of the fuse body, loosening of the terminals or excessive corrosion of the leads. The DC resistance shall not change by more than 15 percent as a result of the moisture exposure.

AEM, Inc.	6610 COBRA WAY SAN DIEGO, CA 92121	TITLE P600L SPECIFICATION
NUMBER P600L	REVISION M	ECN 2184
		SHEET 4 of 27

4.8.11 Shock (Group C / Qualification Only). When fuses are tested in accordance with 5.8.10, there shall be no evidence of mechanical damage and the DC resistance shall not change by more than 10 percent.

4.8.12 Vibration (Group C / Qualification Only). When fuses are tested in accordance with 5.8.11, there shall be no evidence of mechanical damage and the DC resistance shall not change by more than 10 percent.

4.8.13 Low Temperature Operation (Group C / Qualification Only). When fuses are tested in accordance with 5.8.13, they shall not open circuit and the DC resistance shall not change by more than 10 percent.

4.8.14 Life (2000 Hours, Group C / Qualification Only). When fuses are tested in accordance with 5.8.14, they shall not open circuit and the DC resistance shall not change by more than 10 percent.

4.8.15 Resistance to Soldering Heat (Group C / Qualification Only). When fuses are tested in accordance with 5.8.12, there shall be no mechanical damage and the DC resistance shall not change by more than 10 percent.

4.8.16 Solderability. Fuses shall meet the solderability requirements specified in MIL-STD-202, Method 208. Prior to testing, gold plated leads shall have the gold removed by single or double dipping into a flowing or nonflowing hot solder of sufficient volume to assure complete gold removal.

4.8.17 Salt Spray (Group C / Qualification Only). When fuses are tested in accordance with 5.8.18, there shall be no evidence of excessive corrosion. Excessive corrosion is defined as that which interferes with the electrical or mechanical performance. There shall be no warping or cracking of the fuse body and the DC resistance shall not change by more than 10 percent.

4.8.18 Outgassing (Qualification Only). When fuses are tested in accordance with 5.8.19, the materials shall meet the following requirements:

- a) Total mass loss (TML) - Shall not exceed 1.0 percent.
- b) Collected volatile condensable material (CVCM) - Shall not exceed 0.1 percent.

4.8.19 Short Circuit Interrupt (Group C / Qualification Only). When fuses are tested in accordance with 5.8.20, the DC resistance after short circuit testing shall be at least 1.0 megohm.

4.9 Workmanship. Fuses shall meet the visual and mechanical criteria outlined in AEM Process Instructions P70617 and P70765 when inspected per 5.8.1.

4.9.1 Precap Inspection. Prior to molding all fuses shall be visually inspected with a minimum of 10 power magnification. Inspection criteria are outlined in the AEM Precap Document P600L-PA.

5. QUALITY ASSURANCE PROVISIONS

5.1 Classification of Inspection. The inspection of fuses procured to the requirements of this specification shall be classified as follows:

- a) Qualification Inspection (paragraph 5.6) when specified on the purchase order.
- b) Acceptance Inspection (paragraph 5.7).

5.2 Reliability Assurance Program. AEM shall ensure that a reliability assurance program and Quality Management System are established and maintained in accordance with MIL-STD-790 and AS9100.

5.3 Test Equipment and Inspection Facilities. AEM shall establish and maintain a calibration system in accordance with NCSL Z540.3 and MIL-STD-45662.

5.4 Acceptance Inspection Reports. AEM shall supply with each shipment of fuses the following minimum data:

AEM, Inc.	6610 COBRA WAY SAN DIEGO, CA 92121	TITLE P600L SPECIFICATION
NUMBER P600L	REVISION M	ECN 2184
		SHEET 5 of 27

- a) All variables data accumulated during Group A and Group B inspections. Group C data, if required on the purchase order, shall be shipped at the completion of Group C inspection;
- b) Customer specified test reports;
- c) Certification of Conformance signed by Quality Assurance Manager.

5.5 Inspection Conditions and Methods. Unless otherwise specified in this document, inspections shall be conducted at room ambient environments of +25°C +/- 5°C and the maximum relative humidity shall be 75 percent.

5.6 Qualification Inspection.

5.6.1 Qualification Samples. Samples submitted to qualification inspection shall be representative of the normal high reliability production. A sample of 32 fuses representing the lowest, middle, and highest voltage drops within the truncated distribution shall be submitted for qualification inspection. At the completion of Subgroup I inspection, the 32 samples shall be divided into the subgroups and quantities shown in Table V. Each subgroup shall have approximately equal representation of the fuse voltage drops.

5.7 Acceptance Inspection.

5.7.1 Inspection of Fuses for Delivery. Inspection of fuses for delivery against a purchase order shall consist of the tests listed in Table I.

5.7.2 Inspection Lot. An inspection lot shall consist of one amperage rating of one lot date code and one manufacturing lot.

5.7.3 Group A Inspection. Group A inspection shall consist of the tests listed in Table II and shall be conducted in the order indicated.

5.7.4 Group B Inspection. Group B inspection shall consist of the tests listed in Table III and shall be conducted in the order indicated. All fuses submitted to Group B inspection shall have successfully met all electrical requirements of the Group A inspection (Visual rejects and X-Ray rejects may be utilized for Group B inspection).

5.7.5 Group C Inspection. Group C inspection, when required by the purchase order, shall consist of the tests listed in Table IV. The fuses submitted for Group C inspection shall have met Group A and Group B inspection requirements as part of the inspection lot from which they were taken.

AEM, Inc.	6610 COBRA WAY SAN DIEGO, CA 92121	TITLE P600L SPECIFICATION
NUMBER P600L	REVISION M ECN 2184	SHEET 6 of 27

TABLE II. GROUP A INSPECTION.

Examination or Test	Requirement Paragraph	Method Paragraph	Number of Units Specified	Number of Defectives Allowed
Precap Inspection	4.9.1		100%	N/A
Visual and Mechanical Examination	4.9	5.8.1	100%	N/A
Thermal Shock	4.8.1	5.8.3	100%	(Note 1)
Burn-in	4.8.2	5.8.4	100%	(Note 1)
DC Resistance	4.6	5.8.2	100%	N/A
Overload Current Characterization	4.8.8.1	5.8.15	As Required (20 pcs. Minimum)	N/A
X-Ray Inspection	4.8.4	5.8.6	100%	N/A
Visual and Mechanical Inspection	4.9	5.8.1	100%	N/A
Dielectric Strength	4.8.3	5.8.4	MIL-PRF-23419	0

Notes:

1. The maximum PDA for the Thermal Shock and Burn-in Tests combined is 5%.

AEM, Inc.	6610 COBRA WAY SAN DIEGO, CA 92121	TITLE P600L SPECIFICATION
NUMBER P600L	REVISION M ECN 2184	SHEET 7 of 27

TABLE III. GROUP B INSPECTION.

Examination or Test (See Note 3)	Requirement Paragraph	Method Paragraph	Number of Units Specified (Notes 1 and 2)	Number of Defectives Allowed
Terminal Strength	4.8.6	5.8.8	20	0
Overload Current @ (+25°C)	4.8.8.2	5.8.15	20	0
Resistance after Firing	4.8.9	5.8.16	20	0
Solderability	4.8.16		20	0

Notes:

1. Overload Current test sample shall be:
 250% Overload Sample: 12 Samples
 400% Overload Current: 4 Samples
 600% Overload Current: 4 Samples
2. For lot sizes over 1200 fuses, the Group B Sample size shall be 23 fuses. In such a case, 1 additional sample will be tested at each overload level identified in Note 1 above.
3. When testing SK406 style fuses (formed terminal option), the testing sequence shall be: Solderability, Terminal Strength, Overload Current, and Resistance after Firing.

AEM, Inc.	6610 COBRA WAY SAN DIEGO, CA 92121	TITLE P600L SPECIFICATION
NUMBER P600L	REVISION M ECN 2184	SHEET 8 of 27

TABLE IV. GROUP C INSPECTION.

Examination or Test	Requirement Paragraph	Method Paragraph	Number of Units Specified	Number of Defectives Allowed
Subgroup I (16 Units)				
Low Temperature Operation	4.8.13	5.8.13	12	0
Life (2000 Hours)	4.8.14	5.8.14	12	0
Overload Current	4.8.8.2	5.8.15	12	0
Resistance After Firing	4.8.9	5.8.16	12	0
Short Circuit Interrupt	4.8.19	5.8.20	4	0
Resistance after Firing	4.8.9	5.8.16	4	0
Subgroup II (6 Units)				
Terminal Strength	4.8.6	5.8.8	6	0
Overload Current @ High/Low Temps and Max. Clearing at 600%	4.8.8.2	5.8.15	6	0
Resistance after Firing	4.8.9	5.8.16	6	0
Subgroup III (4 Units)				
Vibration	4.8.12	5.8.11	4	0
Shock	4.8.11	5.8.10	4	0
Resistance to Soldering Heat	4.8.15	5.8.12	4	0
Subgroup IV (4 Units)				
Salt Spray	4.8.17	5.8.18	4	0
Overload Current @ +25°C and Max. Clearing at 600%	4.8.8.2	5.8.15	4	0
Resistance after Firing	4.8.9	5.8.16	4	0
Subgroup V (4 Units)				
Moisture Resistance	4.8.10	5.8.9	4	0
5-Cycle Thermal Shock	4.8.1	5.8.3	4	0
Current Carrying Capacity (+25°C)	4.8.5	5.8.7	4	0

AEM, Inc.	6610 COBRA WAY SAN DIEGO, CA 92121	TITLE P600L SPECIFICATION	
NUMBER P600L	REVISION M	ECN 2184	SHEET 9 of 27

TABLE V. QUALIFICATION INSPECTION.

Examination or Test	Requirement Paragraph	Method Paragraph	Number of Units Specified	Number of Defectives Allowed
Subgroup I (32 Units)				
Visual and Mechanical Examination	4.9	5.8.1	All	0
DC Resistance	4.6	5.8.2	All	0
Current-Carrying Capacity	4.8.5	5.8.7	All	0
Subgroup II (6 Units)				
Terminal Strength	4.8.6	5.8.8	6	0
Overload Current @High/Low Temps and Max. Clearing at 600%)	4.8.8.2	5.8.15	6	0
Resistance after Firing	4.8.9	5.8.16	6	0
Solderability	4.8.16		6	0
Subgroup III (14 Units)				
Low Temperature Operation	4.8.13	5.8.13	6	0
Life (2000 Hours)	4.8.14	5.8.14	6	0
Overload Current	4.8.8.2	5.8.15	6	0
Resistance After Firing	4.8.9	5.8.16	6	0
Thermal Vacuum	4.8.7	5.8.17	4 (Separate Sample)	0
Overload Current (400%)	4.8.8.2	5.8.15	2	0
Resistance after Firing	4.8.9	5.8.16	2	0
Short Circuit Interrupt	4.8.19	5.8.20	4 (Separate Sample)	0
Resistance After Firing	4.8.9	5.8.16	4	0
Subgroup IV (4 Units)				
Vibration	4.8.12	5.8.11	4	0
Shock	4.8.11	5.8.10	4	0
Subgroup V (4 Units)				
Salt Spray	4.8.17	5.8.18	4	0
Overload Current @+25°C (Max. Clearing at 600%)	4.8.8.2	5.8.15	4	0
Resistance After Firing	4.8.9	5.8.16	4	0
Subgroup VI (4 Units)				
Outgassing	4.8.18	5.8.19	4	4
Moisture Resistance	4.8.10	5.8.9	4	0
5-Cycle Thermal Shock	4.8.1	5.8.3	4	0
Resistance to Soldering Heat	4.8.15	5.8.12	4	0
Current Carrying Capacity (+25°C)	4.8.5	5.8.7	4	0
Overload Current (+25°C)	4.8.8.2	5.8.15	4	0
Resistance After Firing	4.8.9	5.8.16	4	0

AEM, Inc.	6610 COBRA WAY SAN DIEGO, CA 92121	TITLE P600L SPECIFICATION
NUMBER P600L	REVISION M ECN 2184	SHEET 10 of 27

TABLE VI. ELECTRICAL AND MECHANICAL REQUIREMENTS.

FUSE PART NUMBER / RATINGS			DC RESISTANCE (OHMS) 1/		FIGURE (1, 2, OR 3)	OVERLOAD INTERRUPT TIME (SECONDS) 2/			MAXIMUM I ² T (AMPERE ² SECONDS) 3/					
P600L PART NO.	MAXIMUM VOLTAGE (VDC)	CURRENT RATING (AMPS)	MINIMUM	MAXIMUM		250 % NOMINAL RATING	400 % NOMINAL RATING	600% NOMINAL RATING	250 % NOMINAL RATING	400 % NOMINAL RATING	600% NOMINAL RATING			
P600L-72-1/8	72	1/8	6.375	10.625	1	.005-30.0	.0005-.015	.000075-.003	2.930	0.004	0.002			
P600L-72-1/4	72	1/4	1.875	3.125	1	.005-30.0	.0005-.015	.000075-.003	11.719	0.015	0.007			
P600L-72-3/8	72	3/8	1.125	1.875	1	.01-.300	.001-.015	.00015-.003	0.264	0.034	0.015			
P600L-72-1/2	72	1/2	0.675	1.125	1	↑	↑	↑	0.469	0.060	0.027			
P600L-72-3/4	72	3/4	0.225	0.375	1				1.055	0.135	0.061			
P600L-72-1.0	72	1.0	0.135	0.225	1				1.875	0.240	0.108			
P600L-72-1.5	72	1.5	0.097	0.163	1				4.219	0.540	0.243			
P600L-72-2.0	72	2.0	0.045	0.075	1				7.500	0.960	0.432			
P600L-72-3.0	72	3.0	0.0262	0.0438	1				16.875	2.160	0.972			
P600L-72-4.0	72	4.0	0.0195	0.0325	1				30.000	3.840	1.728			
P600L-72-5.0	72	5.0	0.0135	0.0225	1				46.875	6.000	2.700			
P600L-72-6.0	72	6.0	0.0112	0.0188	1				67.500	8.640	3.888			
P600L-72-7.5	72	7.5	0.0082	0.0138	1				105.469	13.500	6.075			
P600L-72-10.0	72	10.0	0.0063	0.0107	2	187.500	24.000	10.800						
P600L-72-15.0	72	15.0	0.0040	0.0070	2	.01-.300	.001-.015	.00015-.003	421.875	54.000	24.300			
P600L-125-1/8	125	1/8	6.375	10.625	1	.005-30.0	.0005-.015	.000075-.003	2.930	0.004	0.002			
P600L-125-1/4	125	1/4	1.875	3.125	1	.005-30.0	.0005-.015	.000075-.003	11.719	0.015	0.007			
P600L-125-3/8	125	3/8	1.125	1.875	1	.01-.300	.001-.015	.00015-.003	0.264	0.034	0.015			
P600L-125-1/2	125	1/2	0.675	1.125	2	↑	↑	↑	0.469	0.060	0.027			
P600L-125-3/4	125	3/4	0.225	0.375	2				1.055	0.135	0.061			
P600L-125-1.0	125	1.0	0.090	0.270	2				1.875	0.240	0.108			
P600L-125-1.5	125	1.5	0.085	0.225	2				4.219	0.540	0.243			
P600L-125-2.0	125	2.0	0.045	0.135	2				7.500	0.960	0.432			
P600L-125-3.0	125	3.0	0.035	0.105	2				16.875	2.160	0.972			
P600L-125-4.0	125	4.0	0.030	0.090	2				30.000	3.840	1.728			
P600L-125-5.0	125	5.0	0.022	0.068	2				46.875	6.000	2.700			
P600L-50-20.0	50	20.0	0.0025	0.0050	3				.01-.300	.001-.015	.00015-.003	750.000	96.000	43.200

1/ DC RESISTANCE IS MEASURED AT CURRENT LEVELS LESS THAN OR EQUAL TO 10% OF RATED CURRENT.

2/ OVERLOAD INTERRUPT TIMES AT -55 C AND 250% OVERLOAD CURRENT SHALL BE AS FOLLOWS:

- a) FUSES WITH RATINGS LESS THAN 3/8 AMPERES SHALL OPEN IN 60 SECONDS MAXIMUM.
- b) FUSES WITH RATINGS FROM 3/8 TO 1.0 AMPERE SHALL OPEN IN 10 SECONDS MAXIMUM.
- c) FUSES WITH RATINGS GREATER THAN 1.0 AMPERE SHALL OPEN IN 5 SECONDS MAXIMUM.

3/ MAXIMUM I²T AT -55 C AND 250% OVERLOAD CURRENT MAY BE GREATER THAN INDICATED. TO CALCULATE MAXIMUM I²T AT A CASE TEMPERATURE OF -55 C AND 250% OVERLOAD CURRENT, MULTIPLY THE I²T PRODUCT BY THE MAXIMUM BLOW TIMES INDICATED IN NOTE 2 ABOVE.

4/ P600L-125 OPTIONS ARE ALSO AVAILABLE AS 135VDC FUSES.

- a) P600L-135 OPTIONS WILL HAVE THE SAME ELECTRICAL REQUIREMENTS AS P600L-125 OPTIONS EXCEPT THAT OVERLOAD CURRENT TESTING IS CONDUCTED AT 135 VDC LEVELS.
- b) P600L-135 OPTIONS WILL BE PACKAGED AS NOTED IN THE TABLE ABOVE (EXCEPT THAT PART MARKING WILL REFLECT 135 VDC RATHER THAN 125 VDC).
- c) NONSTANDARD 125/135 VDC P600L FUSES ARE ALSO AVAILABLE WITH AMPERAGE RATINGS OF 7.5, 10.0 AND 15.0 AMPERES.
 P600L-125/135-7.5 (SEE AEM DRAWING 487034)
 P600L-125/135-10.0 (SEE AEM DRAWING 487036)
 P600L-125/135-15.0 (SEE AEM DRAWING 487035)

5/ P600L-72 OPTIONS ARE ALSO AVAILABLE AS 80VDC FUSES (SEE AEM DRAWING 487072).

AEM, Inc.		6610 COBRA WAY SAN DIEGO, CA 92121		TITLE P600L SPECIFICATION	
NUMBER P600L	REVISION M	ECN 2184	SHEET 11 of 27		

5.8 Methods of Examination and Test.

5.8.1 Visual and Mechanical Inspection. Fuses shall be visually and mechanically examined per AEM Process Instruction P70617 following the molding operation. Fuses shall be visually and mechanically examined per AEM Process Instruction P70765 following the final assembly marking and sealing operations.

5.8.2 DC resistance. The resistance of the fuse shall be measured using a constant current DC source having an open circuit voltage not greater than the voltage rating of the fuse. The measurement current shall be measured with a test current not exceeding 10 percent of the nominal fuse rating and provide a measurement accuracy of +/- 1%. A Keithley Model 580 or equivalent is recommended for these measurements. Measurements shall be taken at room ambient conditions as close to the fuse element as is possible.

5.8.3 Thermal Shock. Fuses shall be tested in accordance with Method 107, Test Condition B, of MIL-STD-202. A total of five cycles shall be run without interruption. The voltage drops of the fuses shall be measured before the five cycles in accordance with 5.8.4.1. The burn-in test of 5.8.4 shall follow this test.

5.8.4 Burn-in. Fuses shall be mounted by their terminals in suitable mount sockets. Spacing between each fuse shall not be less than 0.1 inches or greater than 1 inch. Fuses shall be electrically connected to a constant DC source supplying rated current through each fuse. Current shall be applied for 168 +4 / -0 hours while at room ambient conditions (+25°C to +28°C). Forced air shall not flow over the fuses during this burn-in period. The voltage drop of each fuse shall be measured in accordance with 5.8.4.1 after the burn-in period with the voltage drop change determined from the measurement taken before the thermal shock test of 5.8.3.

5.8.4.1 Voltage Drop at Rated Current. The voltage drop of the fuse shall be measured at room ambient conditions while rated DC current is flowing through the fuse. The measurement shall be made to +/- 1 percent accuracy with the voltage probes placed as close to the fuse element as is practical.

5.8.5 Dielectric Strength. Fuses shall be tested in accordance with Method 301 of MIL-STD-202. Fuses shall be mounted in a test fixture capable of exposing all major surfaces of the fuse body and leads to the test voltage. The test voltage shall be applied to the terminals electrically tied together and to the test fixture. The following details shall apply:

- a) Test voltage - 500 VRMS;
- b) Duration - 5 seconds for acceptance tests;
- 60 seconds for qualification tests;
- c) Leakage current - 1 milliamper maximum;
- d) Measurements - DC resistance of the fuse after the dielectric strength exposure in accordance with 5.8.2.

5.8.6 X-Ray Inspection. Fuses shall be subjected to radiographic inspection in accordance with Method 209 of MIL-STD-202. The following details shall apply:

- a) The radiograph shall be of sufficient quality to render a clear, sharp image of the penetrameter.
- b) The source-object distance shall ensure a sharply defined image.
- c) Two views of each fuse (0° and 90°) shall be provided.
- d) A radiograph penetrameter shall be included on each radiographic film.
- e) Radiographs shall be examined at 10X magnification for the defects specified in AEM P600L-R Specification.

AEM, Inc.	6610 COBRA WAY SAN DIEGO, CA 92121	TITLE P600L SPECIFICATION
NUMBER P600L	REVISION M	ECN 2184
		SHEET 12 of 27

5.8.7 Current-Carrying Capacity (Group C / Qualification Only). Fuse samples shall be apportioned and submitted to the following DC test currents at -55°C to -60°C, at +20°C to +35°C (room ambient temperature), and at +125°C to +130°C:

<u>Test Temperature</u>	<u>DC Test Current</u>
- 55°C	110% of Rated
+ 25°C	100% of Rated
+ 125°C	80% of Rated

The test current shall be maintained for 30 minutes after the temperature of each fuse has stabilized, but shall not be applied for less than 1.5 hours. It may be assumed that the temperature has stabilized when three consecutive temperature readings taken at 10 minute intervals show no rise in temperature. The temperature of the fuse body shall be measured by thermocouples (wire size 28 to 32 AWG).

5.8.8 Terminal Strength. Fuses shall be tested in accordance with Method 211 of MIL-STD-202. The following exceptions shall apply:

- a) Test Condition - Test Condition A (5 lbs pull) applying the force axially to each lead wire individually, then Test Condition C (1 lb force) applying three bends to each wire terminal.
- b) Method of Holding - The fuse body shall be held by means other than rigid clamping to prevent stresses from being transferred to the fuse element.
- c) Measurements - DC resistance measurements shall be taken before and after exposure in accordance with 5.8.2.

5.8.9 Moisture Resistance (Group C / Qualification Only). Fuses shall be tested in accordance with Method 106 of MIL-STD-202. The following exceptions shall apply:

- a) Mounting - Normal mounting means on a noncorrosive metal panel positioned 15 degrees from the vertical with the terminals down.
- b) Polarizing voltage shall be 100 volts DC.
- c) Steps 7a and 7b are not applicable.
- d) Measurements - DC resistance measurements shall be taken before and after the exposure in accordance with 5.8.2.

5.8.10 Shock (Group C / Qualification Only). Fuses shall be tested in accordance with Method 213 of MIL-STD-202. The following details and exceptions shall apply:

- a) Mounting - Fuses shall be securely fastened to the table of the shock machine to prevent relative motion between the fuses and the table.
- b) Test Condition - F (except 1500G, 0.5 milliseconds, half-sine)
- c) Loading during Test - Rated DC current on half of the samples tested.
- d) Number of Shocks - Three shocks in each direction of three mutually perpendicular axes (18 shocks total).
- e) Measurements - DC resistance measurements shall be taken before and after the shock exposure in accordance with 5.8.2.

AEM, Inc.	6610 COBRA WAY SAN DIEGO, CA 92121	TITLE P600L SPECIFICATION
NUMBER P600L	REVISION M	ECN 2184
		SHEET 13 of 27

5.8.11 Vibration (Group C / Qualification Only). Fuses shall be tested in accordance with Method 204 of MIL-STD-202. The following details and exceptions shall apply:

- a) Mounting - Fuses shall be securely fastened to the table of the vibration machine to prevent relative motion between the fuses and the table.
- b) Test Level - Sinusoidal vibration from 5 to 3000 hertz, 0.4 inch double amplitude or 30G's peak, whichever is less.
- c) Sweep Rate - Approximately 1/2 octave per minute.
- d) Test Duration - 12 hours total (4 hours in each of three major axes).
- e) Loading during Testing - Rated DC current on half of the samples tested.
- f) Measurements - DC resistance measurements shall be taken before and after the vibration exposure in accordance with 5.8.2.

5.8.12 Resistance to Soldering Heat (Group C / Qualification Only). Fuses shall be tested in accordance with Method 210 of MIL-STD-202. The following exceptions shall apply:

- a) The leads shall have the gold removed by single or double dipping into a flowing or nonflowing hot solder of sufficient volume to assure complete gold removal. Both leads shall be dipped in type A flux per J-STD-004 for a period of 5 +/- 2 seconds, after which they shall be pre-tinned by immersion into solder for 3 to 5 seconds. The solder shall be maintained at 260°C +/- 5°C. The leads shall be immersed to within .050 inches of the body of the fuse.
- b) Test Condition B.
- c) Cooling Time - Five minutes minimum.
- d) Measurements - DC resistance measurements shall be taken before and after soldering heat exposure in accordance with 5.8.2.
- e) Examination after Test - Fuses shall be examined at a 7X magnification for evidence of mechanical damage.

5.8.13 Low Temperature Operation (Group C / Qualification Only). Fuses shall be mounted by their terminals in sockets and placed in a low temperature chamber. The chamber temperature shall be lowered gradually to -55°C +0/-3°C within a period of 1 hour. After stabilizing at the low temperature for a period of 1 hour, rated DC current shall be applied to the fuses for a period of 4 +1/-0 hours while at the low temperature. The chamber shall then be gradually raised to room temperature within a 4 hour period and maintained at room temperature for a period of 8 hours minimum. After this time, the DC current shall be removed from the fuses and the fuses removed from the chamber. The DC resistance of the fuses shall be measured before and after the test in accordance with 5.8.2.

5.8.14 Life (2000 Hours, Group C / Qualification Only). Fuses shall be mounted by their terminals in sockets and placed in a chamber at +125°C +3/-0°C ambient. The fuses shall be electrically connected to a DC source supplying 64 percent of the +25°C rated current. The current source shall supply an open circuit voltage equal to the voltage rating of the fuses. The fuses shall remain in the chamber at the specified current for 2000 +/- 8 hours. The electrical circuit shall provide a suitable indicator, which shall be monitored daily during the length of the life test, to identify failure (blowing) of any fuse. The time of failure shall be recorded to the nearest +/-12 hours and the blown fuse replaced with a short circuit for the remainder of the test. The DC resistance of the fuses shall be measured before and after the test in accordance with 5.8.2.

AEM, Inc.	6610 COBRA WAY SAN DIEGO, CA 92121	TITLE P600L SPECIFICATION
NUMBER P600L	REVISION M	ECN 2184
		SHEET 14 of 27

5.8.15 Overload Current. Fuses shall be subjected to the applicable percent of DC current (250%, 400% or 600%) specified in Table VI. For Group B and Group C inspections, the fuses shall be tested while at case temperatures of +25°C to +35°C. For Qualification inspection (Subgroup II, Table V) and Group C inspection (Subgroup II, Table IV) the fuses shall be divided equally and tested at -55°C to -60°C, at +25°C to +35°C, and at +125°C to +130°C. The low impedance source shall be adjusted to supply an open circuit voltage equal to the rating of the fuse. The time to "blow" (the interval measured from the application of the current to the time the current drops below the rating of the fuse) shall be measured for each fuse. Each fuse shall remain in the test circuit for 1 minute after the fuse opens to check for restrike conditions. The maximum clearing I²T shall be determined using an oscillogram showing the current trace. The determination shall be made by application of Simpson's rule. A recommended test circuit is shown in Figure 4.

5.8.16 Resistance after Firing. The open resistance of the "blown" fuse shall be measured by applying rated DC voltage across the terminals of the fuse. The resistance value shall be taken after a one-minute application of the test voltage.

5.8.17 Thermal Vacuum (Qualification Only). Fuses shall be mounted in suitable mount sockets. The fuses shall then be placed in a vacuum chamber and the chamber evacuated to a pressure of 5 X 10⁻⁵ torr maximum. The temperature of the fuse mount shall be controlled such that the temperature of the fuses, measured with a thermocouple mounted on the fuse body, is maintained at +125 +/- 3°C for a period of 48 +4/-0 hours, while 90% of the +25°C rated current is flowing through each fuse. At the end of the 48 hour exposure and while the fuses are at the test temperature and pressure, half of the samples shall be given an overload current at 400 percent of their rated current using the procedure specified in 5.8.15. The fuses shall then be removed from the chamber and the remaining fuses (not blown) measured for DC resistance in accordance with 5.8.2.

5.8.18 Salt Spray Corrosion (Group C / Qualification Only). Fuses shall be tested in accordance with Method 101 of MIL-STD-202. The following details shall apply:

- a) Five percent salt solution.
- b) Test Condition B.
- c) Following the drying period, the fuses shall be subjected to 100 percent of rated current for 1 hour.
- d) Following the test the fuses shall be examined for compliance with 4.8.17.

5.8.19 Outgassing (Qualification Only). The fuses or fuse materials shall be tested as specified in ASTM E595.

5.8.20 Short Circuit Interrupt (Group C / Qualification Only). Fuses shall be placed in a DC test circuit capable of supplying a minimum of 1000 amperes. The test circuit shall be made using appropriate generating equipment as a source of power and with the rate of current rise for the test circuit adjusted for at least 3.25 X 10⁶ amperes per second. The open circuit voltage of the test circuit shall be adjusted to a value equal to the maximum rating of the fuse to be tested.

AEM, Inc.	6610 COBRA WAY SAN DIEGO, CA 92121	TITLE P600L SPECIFICATION
NUMBER P600L	REVISION M ECN 2184	SHEET 15 of 27

6. APPLICATIONS

6.1 Parallel Operation. Fuses may be used in parallel operation to gain current-carrying capability. When fuses are to be utilized in parallel configurations, the fuses should be procured as matched sets. The requirements for matched set fuses are indicated below.

- a) Each matched set shall consist of two or more fuses.
- b) Matched set fuses shall be from the same manufacturing lot (same voltage and current rating).
- c) Matched set fuses shall be created by matching individual voltage drops within the set to within 1% (highest to lowest within individual set). The voltage drop values used for matching shall be extracted from the voltage drops taken following the burn-in period.
- d) Matched set fuses shall be marked in accordance with paragraph 4.7, except that an additional matched set serial label shall be placed on the top of each part. Matched set serial labels shall consist of a unique number for each fuse set, followed by a unique letter for each fuse within the set (i.e., 001A, 001B, 001C, 001D; 002A, 002B, 002C, 002D; etc.). Matched fuses may exceed the maximum height dimension by .010 inches as a result of the match set label.
- e) Matched set fuses shall be packaged together, separate from other matched set fuses.
- f) Data generated by the matching requirement shall be included with the standard Group A and B Data Package.
- g) The number of fuses within the matched set shall be specified on the purchase order.
- h) Matched set part numbers shall include the suffix "-MX", where "X" defines the number of fuses in the matched set. As an example: Four electrically matched P600L-72-15.0 fuses shall be ordered as part number P600L-72-15.0-M4 (example defines an equivalent 60 amperes fuse).

6.2 Installation/Terminal Finish. Fuses may be mounted directly onto a printed circuit board or in crimp type receptacles. Bending or twisting of the leads should not be done without mechanically supporting the leads at the exit of the fuse body. For surface mount applications, P600L fuses may be procured as SK406 options. AEM drawing 887108 provides the outline package dimensions for each P600L Figure supplied as an SK406 part type. Group A and B Screening for SK406 part types shall be as specified in this document (except that Solderability is conducted as the first test for Group B). To order a P600L part type in a SK406 lead option, substitute "SK406" for "P600L" in the standard part number.

Example: P600L-72-5.0 (Radial Leaded Format)
 SK406-72-5.0 (Surface Mount Format)

Fuses may be ordered with hot solder dipped terminals (Sn60/Pb40 solder finish). In such a case the component will be ordered with a "T" suffix. AEM drawing 487140 provides additional details.

Example: P600L-72-5.0 (Standard gold plated terminal finish)
 P600L-72-5.0T (Hot solder dipped Sn60/Pb40 terminal finish).

AEM, Inc.		6610 COBRA WAY SAN DIEGO, CA 92121		TITLE P600L SPECIFICATION	
NUMBER	P600L	REVISION	M	ECN	2184
				SHEET 16 of 27	

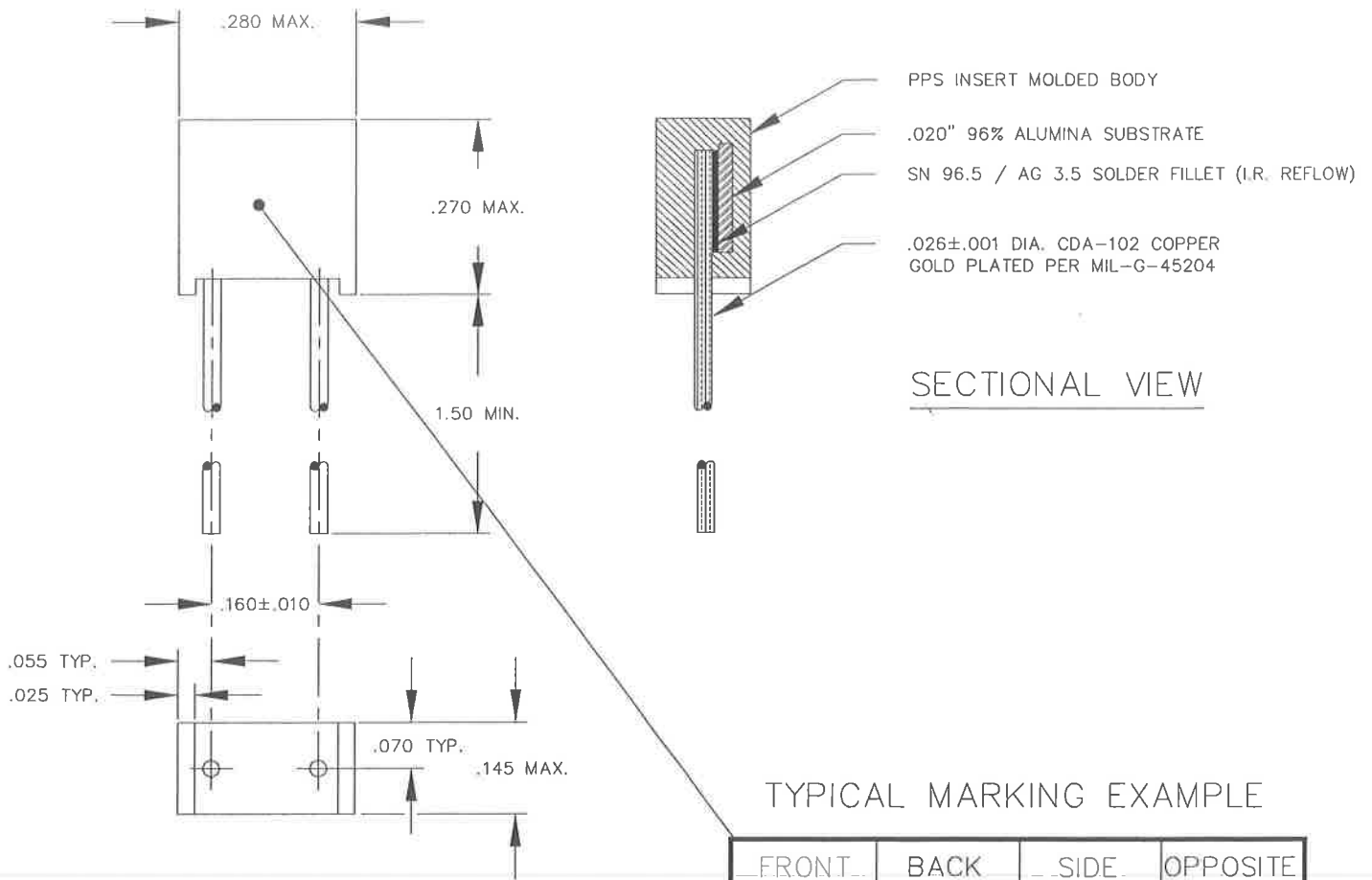

1. Dimensions are in inches.
2. Contour optional within dimensional limits.
3. Lead wire terminals shall be CDA-102 copper.
4. Brady type labels for serial number identification shall be overcoated with Shell Epon overcoat or equivalent.
5. Maximum weight shall be 1.0 gram.
6. Minimum marking shall be abbreviated:

TYPICAL MARKING EXAMPLE

FRONT	BACK	SIDE	OPPOSITE SIDE
P600L	MFG.	SERIAL NO.	LOT CODE
72 VDC	SYMBOL	(XXXXXX)	(C-XXXX)
CURRENT RATING	DATE CODE		

Pin No.: P600L
 Voltage Rating: 72 VDC
 Current Rating: 7.5A (ex.)
 Lot Code: C-XXXX
 AEM Logo: AEM
 Serial No.: 123456 (ex.)

FIGURE 1. DIMENSIONS, CONSTRUCTION AND MARKING.

AEM, Inc.	6610 COBRA WAY SAN DIEGO, CA 92121	TITLE P600L SPECIFICATION	
NUMBER P600L	REVISION M	ECN 2184	SHEET 17 of 27

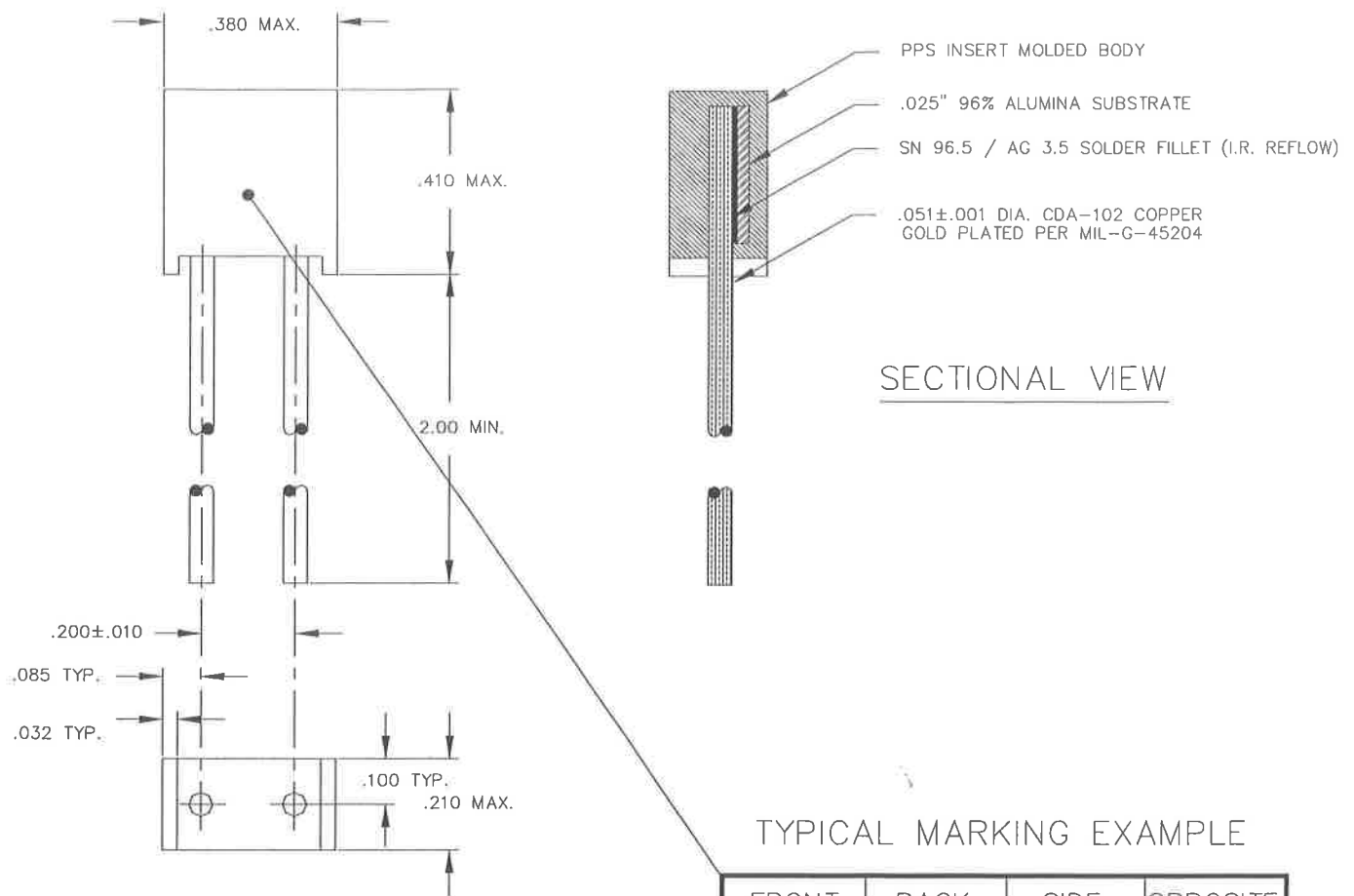

1. Dimensions are in inches.
2. Contour optional within dimensional limits.
3. Lead wire terminals shall be CDA-102 copper.
4. Brady type labels for serial number identification shall be overcoated with Shell Epon overcoat or equivalent.
5. Maximum weight shall be 2.75 grams.
6. Minimum marking shall be abbreviated:

TYPICAL MARKING EXAMPLE

FRONT	BACK	SIDE	OPPOSITE SIDE
P600L 125 VDC CURRENT RATING	MFG. SYMBOL DATE CODE LOT CODE (C-XXXX)	SERIAL NO. (XXXXXX)	

Pin No.: P600L
 Voltage Rating: 125 VDC
 Current Rating: 5A (ex.)
 Lot Code: C-XXXX
 AEM Logo: AEM
 Serial No.: 123456 (ex.)

FIGURE 2. DIMENSIONS, CONSTRUCTION AND MARKING.

AEM, Inc.	6610 COBRA WAY SAN DIEGO, CA 92121	TITLE P600L SPECIFICATION	
NUMBER P600L	REVISION M	ECN 2184	SHEET 18 of 27

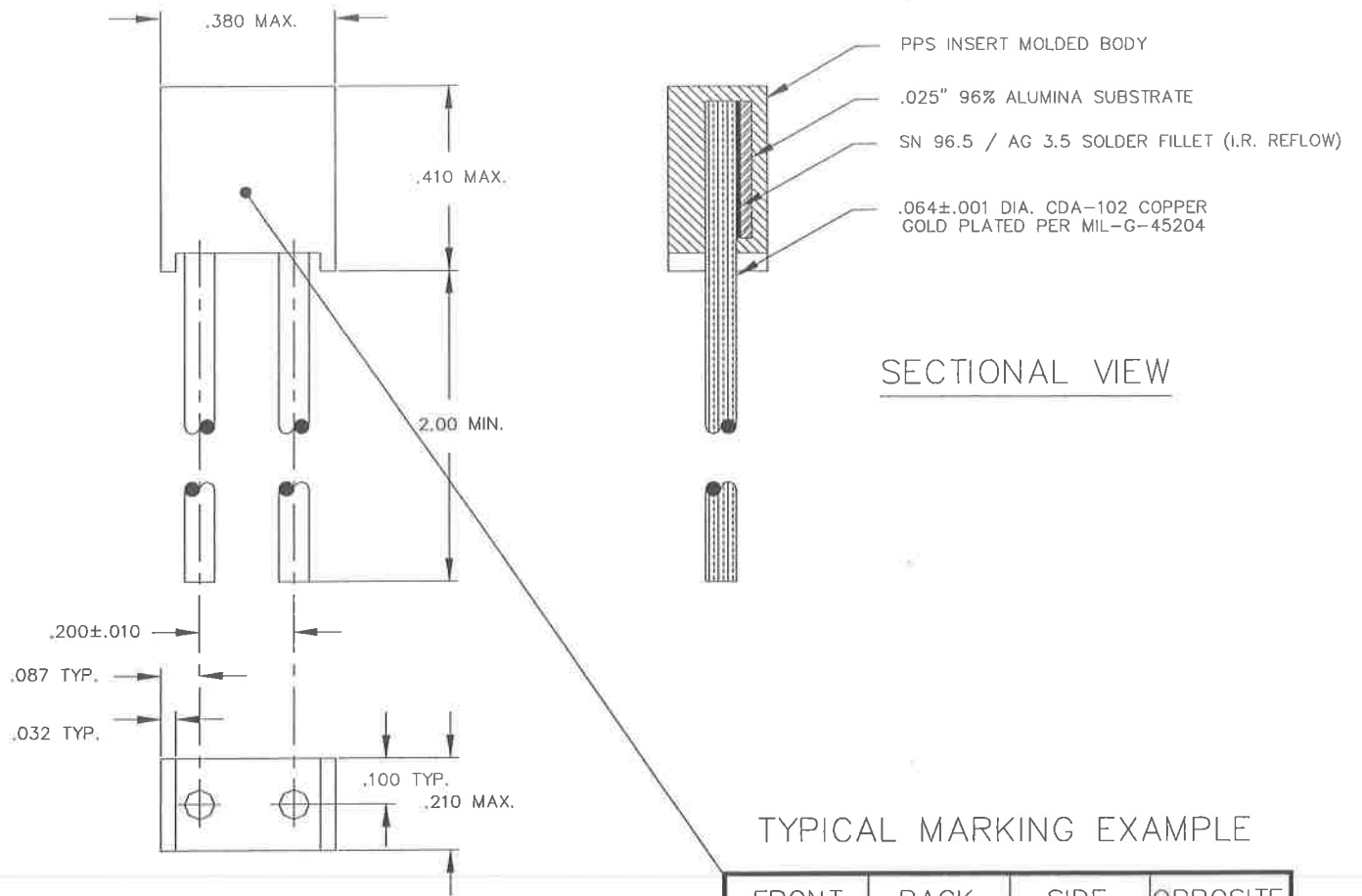

1. Dimensions are in inches.
2. Contour optional within dimensional limits.
3. Lead wire terminals shall be CDA-102 copper.
4. Brady type labels for serial number identification shall be overcoated with Shell Epon overcoat or equivalent.
5. Maximum weight shall be 3.5 grams.
6. Minimum marking shall be abbreviated:

TYPICAL MARKING EXAMPLE

FRONT	BACK	SIDE	OPPOSITE SIDE
P600L 50 VDC CURRENT RATING	MFG. SYMBOL DATE CODE LOT CODE (C-XXXX)	SERIAL NO. (XXXXXX)	

Pin No.: P600L
 Voltage Rating: 50 VDC
 Current Rating: 20A (ex)
 Lot Code: C-XXXX
 AEM Logo: AEM
 Serial No.: 123456 (ex.)

FIGURE 3. DIMENSIONS, CONSTRUCTION AND MARKING.

AEM, Inc.		6610 COBRA WAY SAN DIEGO, CA 92121	TITLE P600L SPECIFICATION
NUMBER P600L	REVISION M	ECN 2184	SHEET 19 of 27

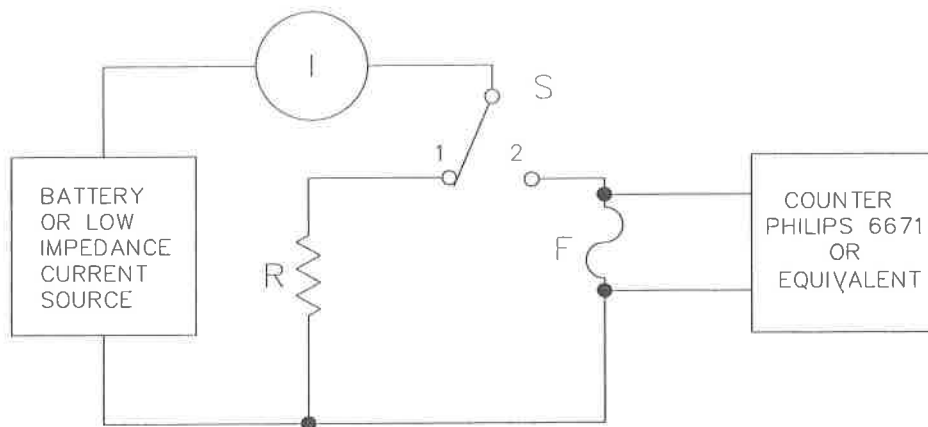

NOTES:

- R = Non-inductive resistor equal to the ohmic value of the fuse being tested.
- S = Non-bounce high current switch.
- I = Current adjusted to percent overload with switch in position 1.
- F = Current limiting fuse under test.

FIGURE 4. OVERLOAD CURRENT TEST CIRCUIT.

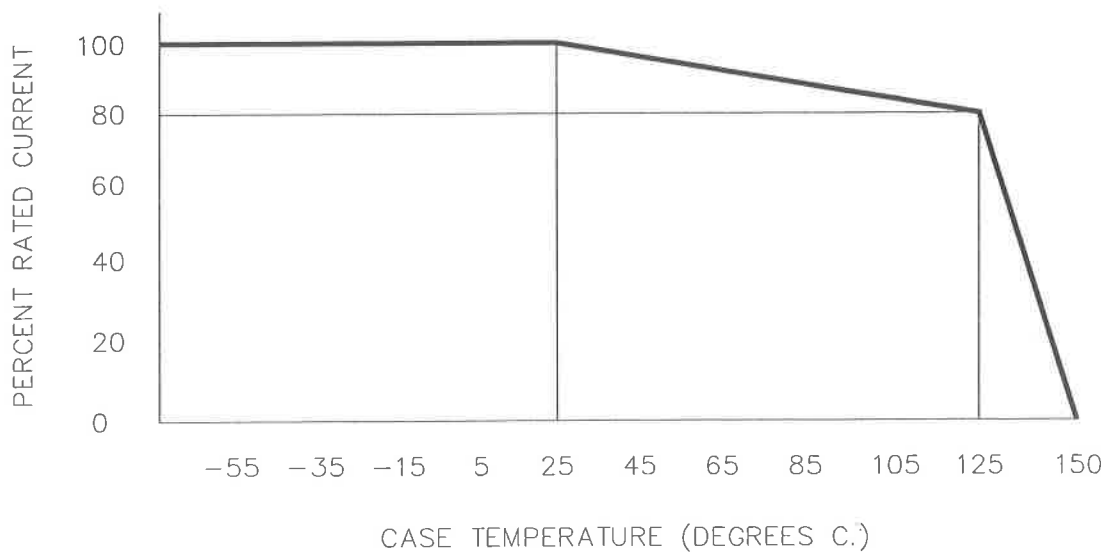
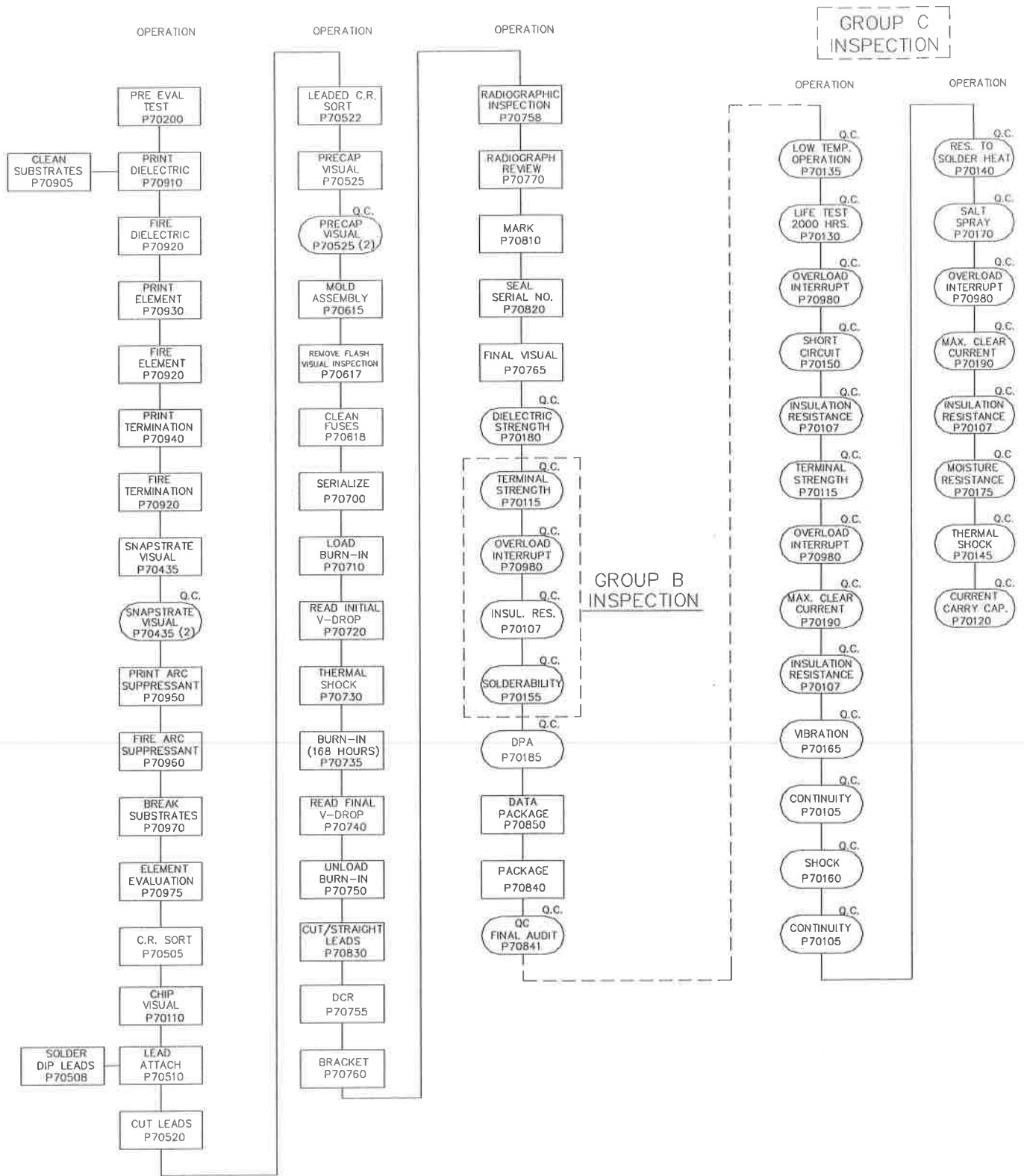

FIGURE 5. CURRENT DERATING LIMITS.

AEM, Inc.		6610 COBRA WAY SAN DIEGO, CA 92121		TITLE P600L SPECIFICATION	
NUMBER	P600L	REVISION	M	ECN	2184
				SHEET 20 of 27	



- 2. Q.C. WILL AUDIT PER MIL-PRF-23419/12, C=0 PLAN.
- 1. FLOW CHART IN ACCORDANCE WITH AEM INC. P600L AND MIL-PRF-23419/12 SPECIFICATIONS.

FIGURE 6. OPERATIONS FLOW CHART.

AEM, Inc.		6610 COBRA WAY SAN DIEGO, CA 92121		TITLE P600L SPECIFICATION	
NUMBER	P600L	REVISION	M	ECN	2184
				SHEET 21 of 27	

DOCUMENT CHANGE NOTICE

<u>REV. LETTER</u>	<u>REV. DATE</u>	<u>PAGE</u>	<u>CHANGE ITEM</u>	<u>APPROVAL</u>
A	11-25-87	N/A	Issued new drawing.	F.D. 11-25-87
B	05-01-90	All	Retyped and renumbered.	J.M. 05-01-90
		4	Para. 1.0: Changed Temp. Rating to -55°C to 150°C.	
		5	Para. 3.3: Added P600L-M Spec.	
		5	Para. 4.5: Changed Temp. Rating to -55°C to 150°C.	
		5	Para. 4.6: Changed test current to 0.1 to 10 milliamperes.	
		6	Para. 4.9.5: Changed TCR from 0.25% to 0.35% per °C.	
		7	Para. 4.9.10: Deleted Note B.	
		8	Para. 5.2: Changed NBS to NIST.	
		14	Para. 5.6.2: Changed test current to 0.1 to 10 milliamperes.	
		14	Para. 5.6.4: Deleted 80% current exception for 10 and 15 amp fuses.	
		15	Para. 5.6.7: Added High Temp. Reference of +125°C.	
		17	Para. 5.6.14: Deleted Heat Sink Requirement.	
		19	Table VI: Added new part numbers for 125 VDC fuses.	
		20	Figure 2: Redrawn.	
		21	Figure 3: Redrawn.	
		22	Figure 4: Flow Chart redrawn to reflect changes in mfg.	
		24	Figure 6: Derating Curve redrawn.	
		25	Para. 6.1: Added reference to P600L-M Spec.	
C	05-01-92	All	Completely retyped and numbered.	J.M. 5-01-92

AEM, Inc.		6610 COBRA WAY SAN DIEGO, CA 92121		TITLE P600L SPECIFICATION	
NUMBER	P600L	REVISION	M	ECN	2184
				SHEET	22 of 27

DOCUMENT CHANGE NOTICE

<u>REV. LETTER</u>	<u>REV. DATE</u>	<u>PAGE</u>	<u>CHANGE ITEM</u>	<u>APPROVAL</u>
		2	Added ref. to MIL-F-23419 and MIL-F-12456.	
		3	Added ref. to MIL-STD-690 and MIL-STD-790.	
		3	Added ref. to MIL-STD-45662 and ASTM E595.	
		3	Para. 4.3: Added 50 VDC ref.	
		4	Para. 4.7: Added ref. to Fig. 3.	
		5	Para. 4.9.6: Added requirement for Current Carrying Capacity.	
		6	Para. 4.9.17: Added requirement for Solderability.	
		6	Para. 4.9.18: Added requirement for Salt Spray.	
		6	Para. 4.9.19: Added requirement for Outgassing.	
		6	Para. 4.9.20: Added requirement for Short Circuit Interrupt.	
		7	Para. 5.2: Added ref. to MIL-STD-790.	
		8	Para. 5.7: Added requirement for FR (Failure Rate) Qualification.	
		9	Table II: Added ref. to MIL-F-23419.	
		10	Table III: Added requirement for Terminal Strength & Solderability.	
		11	Table IV: Reduced number of defective allowed for Subgroup I to 0.	
		12	Table V: Completely revised qualification plan per MIL-F-23419.	
		13	Table VI: Revised cold resistance and clear-time limits for fuses. Added I ² T requirements.	
		14	Added Table VII for FR Qualification.	

AEM, Inc.	6610 COBRA WAY SAN DIEGO, CA 92121	TITLE P600L SPECIFICATION	
NUMBER P600L	REVISION M	ECN 2184	SHEET 23 of 27

DOCUMENT CHANGE NOTICE

<u>REV. LETTER</u>	<u>REV. DATE</u>	<u>PAGE</u>	<u>CHANGE ITEM</u>	<u>APPROVAL</u>
		15	Para. 5.9.4: Changed minimum spacing from 1/2 to 1/4 inch.	
		16	Para. 5.9.8: Added method for Current Carrying Capacity.	
		17	Para. 5.9.10: Change requirement for pull from 2 to 5 pounds.	
		17	Para. 5.9.12: Added requirement for mounting method.	
		17	Para. 5.9.13: Added requirement for mounting method.	
		18	Para. 5.9.14: Added requirement for removal of gold prior to testing.	
		18	Para. 5.9.16: Changed life test temperature from +85°C to +125°C.	
		19	Para. 5.9.17: Added requirement for testing at -55°C and +125°C, and I ² T method for measurement.	
		19	Para. 5.9.19: Changed test temperature from +85°C to +125°C.	
		19	Para. 5.9.20: Added method for Salt Spray Testing.	
		19	Para. 5.9.21: Added method for Outgassing Test.	
		19	Para. 5.9.22: Added method for Short Circuit Testing.	
		21	Figure 1: Changed dimension from 0.275 to 0.280.	
		22	Figure 2: Changed dimension from 0.375 to 0.380.	
		23	Figure 3: New drawing.	
		25	Figure 6: Revised Flow Chart to reflect methods of manufacture.	

AEM, Inc.	6610 COBRA WAY SAN DIEGO, CA 92121	TITLE P600L SPECIFICATION
NUMBER P600L	REVISION M ECN 2184	SHEET 24 of 27

DOCUMENT CHANGE NOTICE

<u>REV. LETTER</u>	<u>REV. DATE</u>	<u>PAGE</u>	<u>CHANGE ITEM</u>	<u>APPROVAL</u>
D	07-11-94	4	Para. 4.9.1: Deleted reference to temperature cycling.	J.M. 7-11-94
		8	Para. 5.8.4: Added note allowing visual and x-ray rejects to be used for Group B tests.	
		13	Table VI: Revised cold resistance limits for 125 VDC fuses rated at 1.5, 2.0, 3.0, 4.0 and 5.0 amps.	
		18	Para. 5.9.14: Changed flux from RMA to R type.	
E	6-5-95	All	Added reference to AEM.	J.M. 6-5-95
		11	Table IV: Added Mil-F-23419 Test Flow (FM12).	
		13	Table VI: Changed cold res. limits for P600L-72-15.0 and P600L-50-20.0 fuse types.	
F	12-18-95	All	Removed all references to Mil-Std-690.	J.M. 12-18-95
		All	Added "Group C / Qualification Only " for all Group C / Qual. test paragraphs.	
		4	Para's 4.6 and 4.8.4: Revised. Removed TCR requirement.	
		5	Para. 4.8.8.1: Changed to 20 samples min.	
		7	Para's 5.3, 5.4 and 5.7.5: Revised.	
		8	Table II: Repositioned DWV test. Added PDA note 1.	
		10	Table IV: Revised to follow Mil-F-23419/12.	
		11	Table V: Revised to follow Mil-F-23419/12.	
		13	Para. 5.8.1: Revised to list AEM Procedures.	
		13	Para. 5.8.4: Revised for part spacing.	
		22	Figure 6: Revised to follow Mil-F-23419/12.	

AEM, Inc.		6610 COBRA WAY SAN DIEGO, CA 92121		TITLE P600L SPECIFICATION
NUMBER P600L	REVISION M	ECN 2184	SHEET 25 of 27	

DOCUMENT CHANGE NOTICE

<u>REV. LETTER</u>	<u>REV. DATE</u>	<u>PAGE</u>	<u>CHANGE ITEM</u>	<u>APPROVAL</u>
G	6-21-96	All	Edited document for improved readability.	J.M. 6-21-96
		2	Para. 1.1: Revised operating temperature range to -55°C to +125°C (was -55°C to +150°C).	
		11	Table V: Revised Subgroup III per FM12 Spec.	
H	1-29-97	22	Updated Figure 6 (ECN 2048)	J.M. 1-31-97
J	11-1-99	3	Removed reference to P600L-M Specification.	J.M. 11/1999
		3	Para. 4.3: Added reference to 135 VDC ratings.	
		11	Table VI: Added note /4 for 135 VDC options.	
		16	Para. 6.1: Added requirements (a – g) for match set fuses.	
		16	Para. 6.2: Added option for SK406 fuses for S.M. applications.	
K		11	Table 6: Corrected Note 4C to reference 487034, 487035 and 487036 (Rev. B for each).	
		16	Para. 6.2: Added reference to drawing revision C for 887108.	
M		1	Revised to indicate 6610 Cobra Way address	J.M. 5/2016
		2-3	Para 3.1: Added reference to AS9100, NCSL Z540.3, J-STD-004, J-STD-006, SAE SAE-AMS2422 and ASTM B488. Removed reference to MIL-F-14256.	
		3	Para. 4.3: Added reference to 80 VDC rating.	
		5	Para. 5.2: Added reference to AS9100.	
		5	Para. 5.3: Added reference to NCSL Z540.3.	
		6	Para. 5.7.5: Removed requirement that Group C be completed with 150 days of Group B completion.	
		8	Table II: Removed reference to "Appendix" as related to Dielectric Strength testing. Added notes 2 and 3 as related to lots over 1200 pcs. and SK406 fuses.	
		9	Table IV: Corrected reference to 4.8.19 in Subgroup I. Added sample references for Max Clearing in Subgroups II and IV.	

AEM, Inc.		6610 COBRA WAY SAN DIEGO, CA 92121		TITLE P600L SPECIFICATION	
NUMBER	P600L	REVISION	M	ECN	2184
				SHEET	26 of 27

DOCUMENT CHANGE NOTICE

<u>REV. LETTER</u>	<u>REV. DATE</u>	<u>PAGE</u>	<u>CHANGE ITEM</u>	<u>APPROVAL</u>
		11	Table VI: Added Note 5 for 80 VDC fuses. Removed references to drawing revisions for 487034, 487035 and 487036 fuses. Revised table column header to indicate DC Resistance as opposed to Cold Resistance.	
		12	Para. 5.8.2: Revised second sentence to indicate that test current not exceed 10 percent of nominal fuse rating.	
		14	Para. 5.8.2: Revised subparagraph "a" to indicate J-STD-004 and Type A flux as opposed to MIL-F-14256 Type R flux.	
		16	Para. 6.1: Added subparagraph "h" for Part number ordering information with -MX suffix.	
		16	Para. 6.2: Added "T" suffix option for fuses supplied with hot solder dipped (Sn60/Pb40) terminal finish.	
		17	Figure 1: Revised example marking to indicate voltage rating prior to current rating.	
		18	Figure 2: Revised example marking to indicate voltage rating prior to current rating.	
		19	Figure 3: Revised example marking to indicate voltage rating prior to current rating.	
		21	Figure 6: Revised Note 2 under table to indicate MIL-PRF-23419/12, C=0 plan, as opposed to MIL-STD-105, Level II, at 1% AQL. Renamed flow chart block DCR as opposed to C.R.	
		All	Header and footer information updated to indicate Revision M and Cobra Way address.	

AEM, Inc.	6610 COBRA WAY SAN DIEGO, CA 92121	TITLE P600L SPECIFICATION
NUMBER P600L	REVISION M ECN 2184	SHEET 27 of 27