



AEM, INC.

P600L-125/135-7.5
CURRENT LIMITING FUSE

SPECIFICATION SHEET FOR NON-STANDARD AEM FUSE PRODUCT

CLEAR-TIME LIMITS

| | |
|---------------|------------------------|
| 250% OVERLOAD | 0.1 - 4.0 SECONDS |
| 400% OVERLOAD | 0.008 - 0.048 SECONDS |
| 600% OVERLOAD | 0.0008 - 0.008 SECONDS |

CURRENT DERATING LIMITS

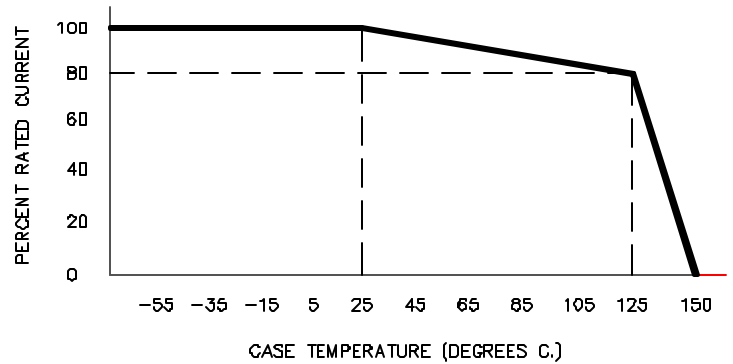

COLD RESISTANCE (+25°C)

0.0165 to 0.0275 OHMS

LOT SCREENING REQUIREMENTS

1. 100% GROUP A INSPECTION PER AEM P600L SPECIFICATION.
2. BURN-IN TESTING CONDUCTED AT 80% RATED CURRENT.
3. X-RAY INSPECTION PER AEM P800L-R SPECIFICATION.
4. GROUP B INSPECTION CONDUCTED PER AEM P600L SPECIFICATION.

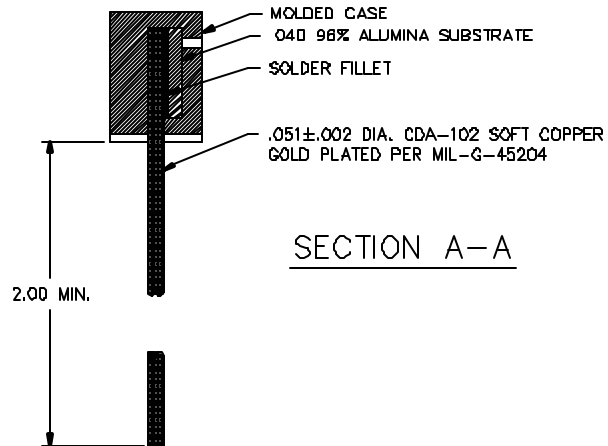
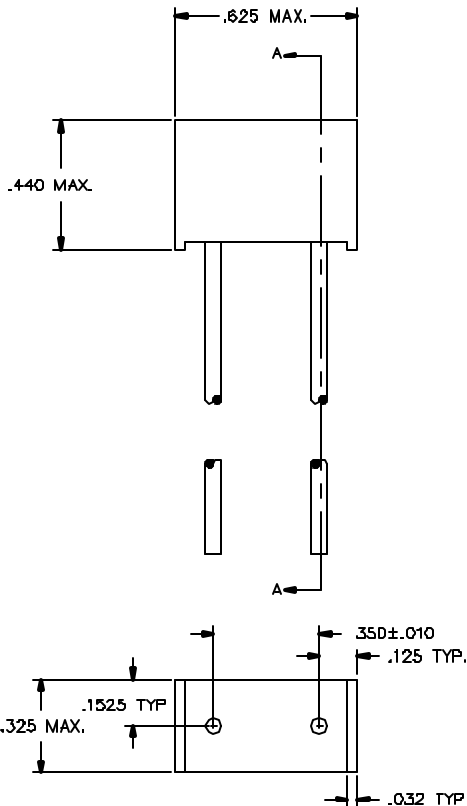

OUTLINE & SECTIONAL VIEW

NOTE:

1. ALL DIMENSIONS ARE IN INCHES

DWG: 487034 REV: C ECN 2129



AEM, INC.

P600L-125/135-15.0 CURRENT LIMITING FUSE

SPECIFICATION SHEET FOR NON-STANDARD AEM FUSE PRODUCT

CLEAR-TIME LIMITS

| | |
|---------------|-----------------------|
| 250% OVERLOAD | 0.1 - 5.0 SECONDS |
| 400% OVERLOAD | 0.01 - 0.06 SECONDS |
| 600% OVERLOAD | 0.001 - 0.010 SECONDS |

CURRENT DERATING LIMITS

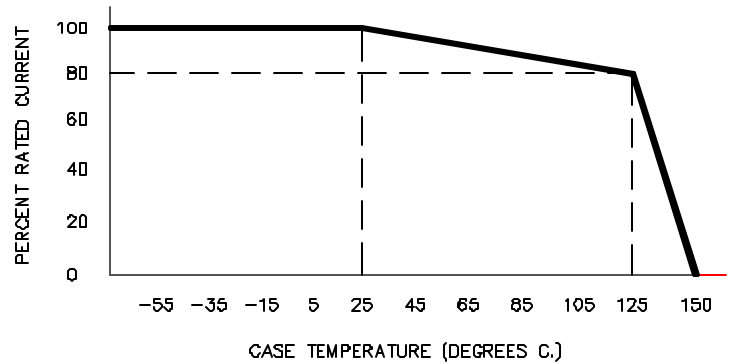

COLD RESISTANCE (+25°C)

0.0090 to 0.0130 OHMS

LOT SCREENING REQUIREMENTS

1. 100% GROUP A INSPECTION PER AEM P600L SPECIFICATION.
2. BURN-IN TESTING CONDUCTED AT 80% RATED CURRENT.
3. X-RAY INSPECTION PER AEM P800L-R SPECIFICATION.
4. GROUP B INSPECTION CONDUCTED PER AEM P600L SPECIFICATION.

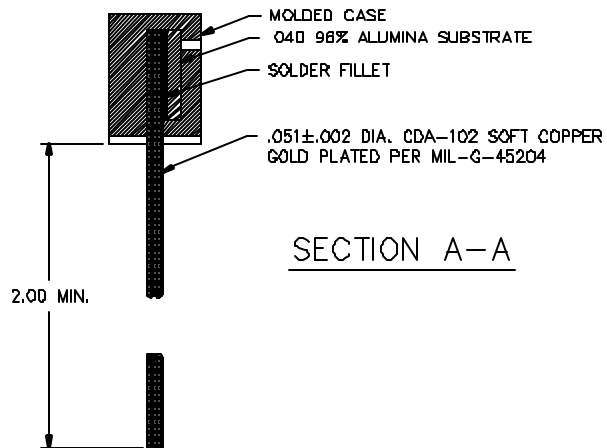
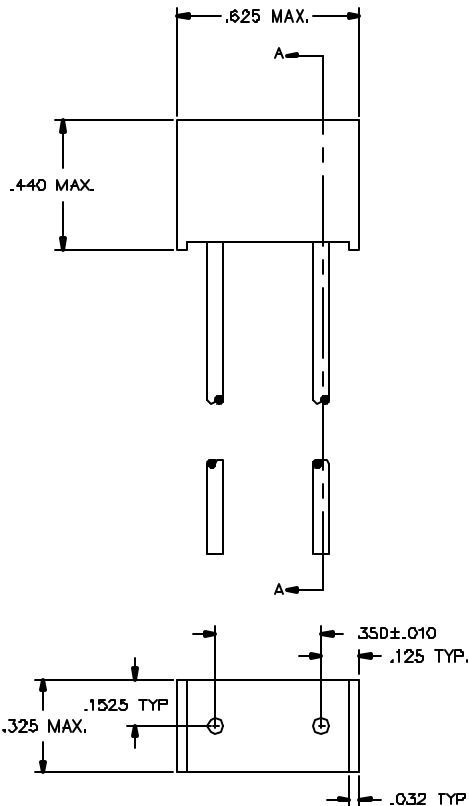

OUTLINE & SECTIONAL VIEW

NOTE:

1. ALL DIMENSIONS ARE IN INCHES.

DWG: 487035 REV: C ECN 2129



AEM, INC.

P600L-125/135-10.0
CURRENT LIMITING FUSE

SPECIFICATION SHEET FOR NON-STANDARD AEM FUSE PRODUCT

CLEAR-TIME LIMITS

| | |
|---------------|------------------------|
| 250% OVERLOAD | 0.1 - 4.0 SECONDS |
| 400% OVERLOAD | 0.008 - 0.048 SECONDS |
| 600% OVERLOAD | 0.0008 - 0.008 SECONDS |

CURRENT DERATING LIMITS

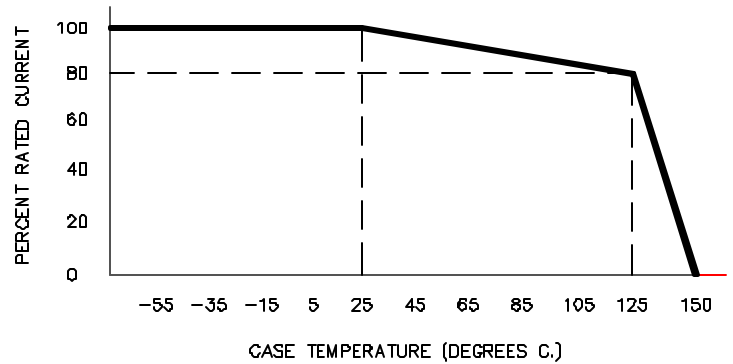

COLD RESISTANCE (+25°C)

0.0120 to 0.0200 OHMS

LOT SCREENING REQUIREMENTS

1. 100% GROUP A INSPECTION PER AEM P600L SPECIFICATION.
2. BURN-IN TESTING CONDUCTED AT 80% RATED CURRENT.
3. X-RAY INSPECTION PER AEM P800L-R SPECIFICATION.
4. GROUP B INSPECTION CONDUCTED PER AEM P600L SPECIFICATION.

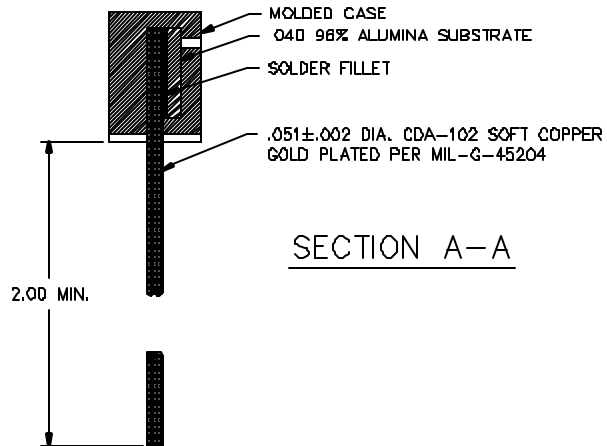
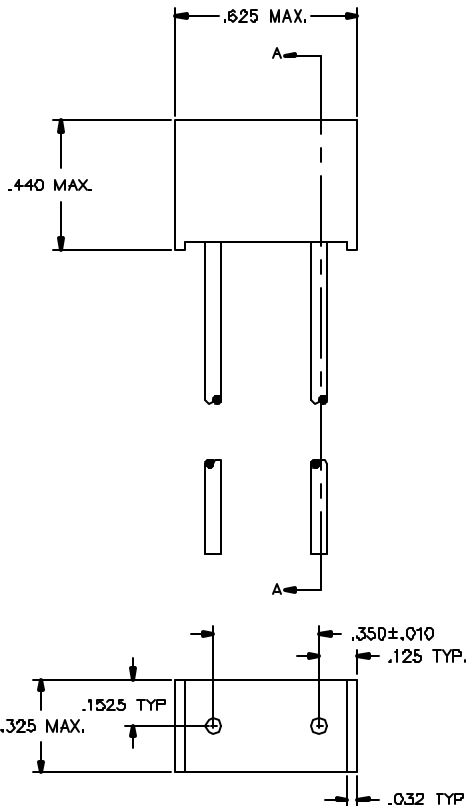

OUTLINE & SECTIONAL VIEW

NOTE:
1. ALL DIMENSIONS ARE IN INCHES.

DWG: 487036 REV: C ECN: 2129